

Form 994-091019

Part Number	Description
PB32HQ	Quad 8-Module Rack with Header Connector for B4 Brain

Description

The PB32HQ I/O mounting rack is designed to mate with the PAMUX 32 channel Brain Board (P/N B4). The PB32HQ I/O mounting rack accommodates up to eight Quad Pak I/O modules for a total of 32 channels of power I/O. The B4 Brain Board plugs into a box connector on the I/O mounting rack and is secured by vertical card guides.

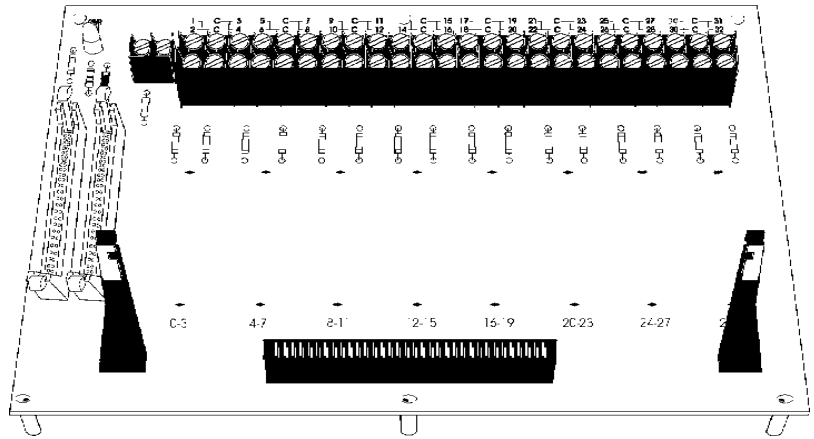

Specifications

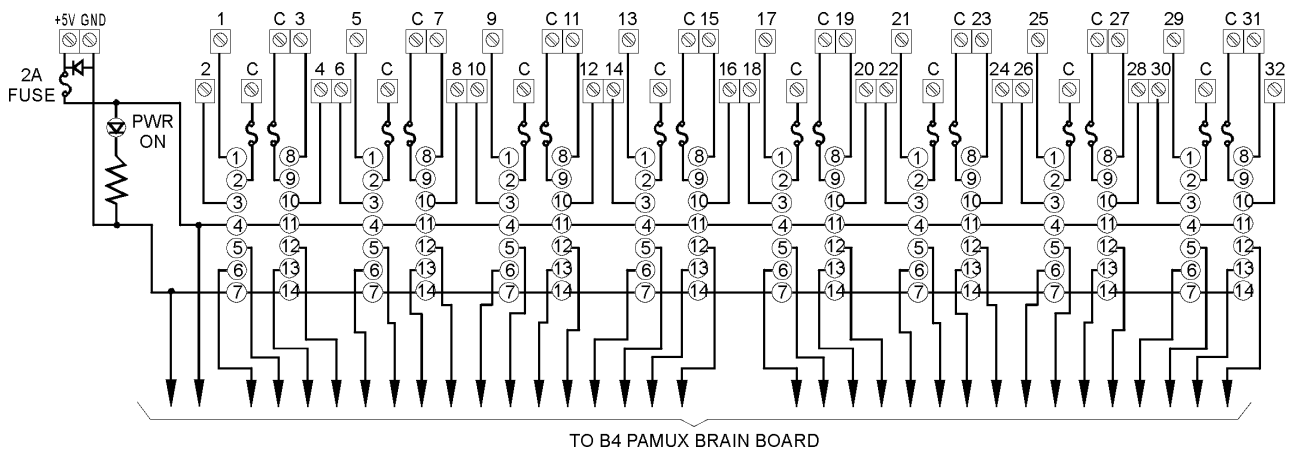

Operating Temperature	0° to 70° 95% relative humidity, non-condensing
Interface Connectors:	
Field	6-32 screw terminals for wires connecting the rack to field devices
Logic	70-pin box connector for brain
Host	50-pin header connector for ribbon cable to host
System	50-pin header connector for ribbon cable to next rack or for termination card on last rack

Schematic



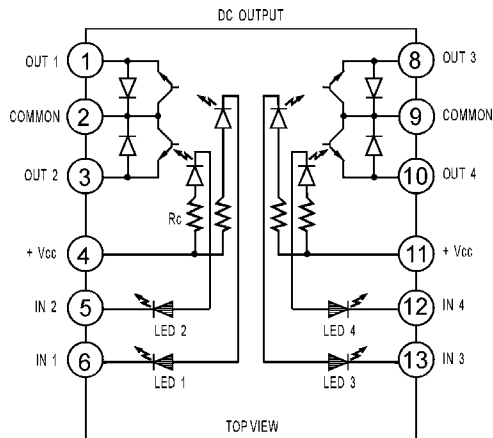

Schematic (Continued)



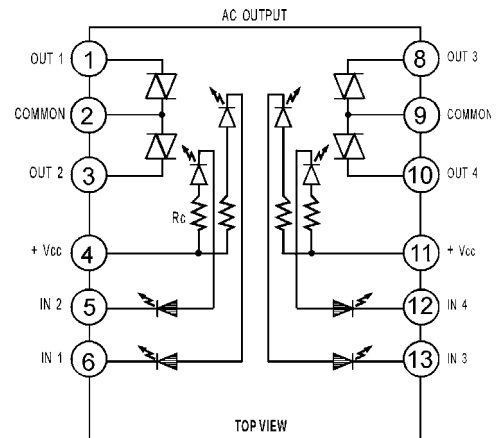

 RED INDICATOR LED
 INFRARED COUPLER LED
 EQUIVALENT CIRCUIT ONLY
 NEGATIVE TRUE LOGIC
 INDUCTIVE LOADS MUST BE
 DIODE SUPPRESSED

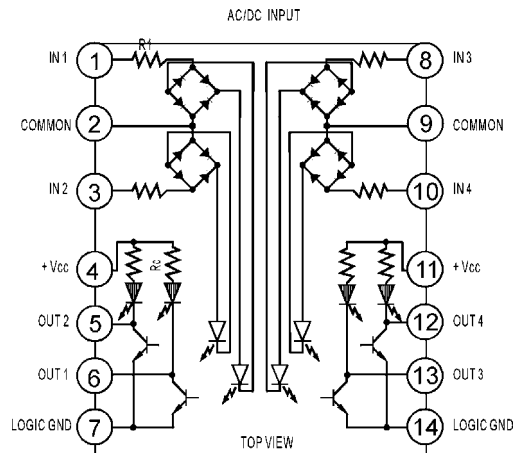

 RED INDICATOR LED
 INFRARED COUPLER LED
 EQUIVALENT CIRCUIT ONLY
 NEGATIVE TRUE LOGIC



 RED INDICATOR LED
 INFRARED COUPLER LED
 EQUIVALENT CIRCUIT ONLY
 NEGATIVE TRUE LOGIC

MOUNTING RACKS CLASSIC QUAD PAK

OPTO 22

DATA SHEET

page 3/4

Form 994-091019

Dimensions

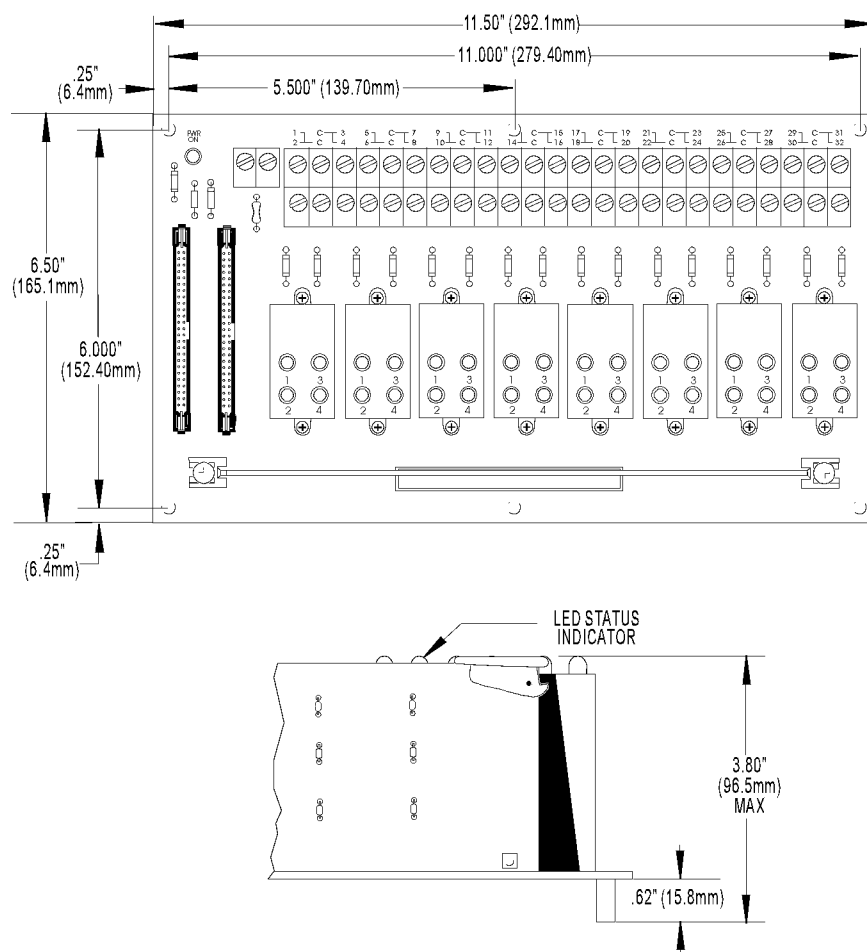

Fuses

The board contains the following fuses:

One 2 amp fuse for 5 volt power on rack (replacement part number FUSE02)

Two 5 amp fuses per module (replacement part number FUSE05)

More About Opto 22

Products

Opto 22 develops and manufactures reliable, flexible, easy-to-use hardware and software products for industrial automation, remote monitoring, and data acquisition applications.

SNAP PAC System

Designed to simplify the typically complex process of understanding, selecting, buying, and applying an automation system, the SNAP PAC System consists of four integrated components:

- SNAP PAC controllers
- PAC Project™ Software Suite
- SNAP PAC brains
- SNAP I/O™

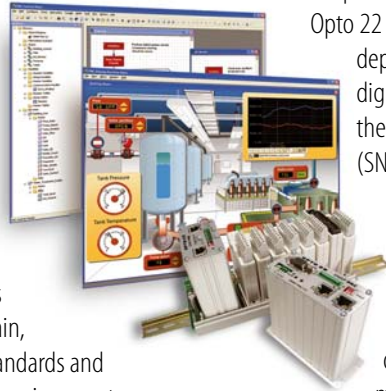

SNAP PAC Controllers

Programmable automation controllers (PACs) are multifunctional, multidomain, modular controllers based on open standards and providing an integrated development environment.

Opto 22 has been manufacturing PACs for many years. The latest models include the standalone SNAP PAC S-series and the rack-mounted SNAP PAC R-series. Both handle a wide range of digital, analog, and serial functions and are equally suited to data collection, remote monitoring, process control, and discrete and hybrid manufacturing.

SNAP PACs are based on open Ethernet and Internet Protocol (IP) standards, so you can build or extend a system without the expense and limitations of proprietary networks and protocols.

PAC Project Software Suite

Opto 22's PAC Project Software Suite provides full-featured and cost-effective control programming, HMI (human machine interface) development and runtime, OPC server, and database connectivity software to power your SNAP PAC System.

These fully integrated software applications share a single tagname database, so the data points you configure in PAC Control™ are immediately available for use in PAC Display™, OptoOPCServer™, and OptoDataLink™. Commands are in plain English; variables and I/O point names are fully descriptive.

PAC Project Basic offers control and HMI tools and is free for download on our website, www.opto22.com. PAC Project Professional, available for separate purchase, adds OptoOPCServer, OptoDataLink, options for Ethernet link redundancy or segmented networking, and support for legacy Opto 22 serial *mistic*™ I/O units.

SNAP PAC Brains

While SNAP PAC controllers provide central control and data distribution, SNAP PAC brains provide distributed intelligence for I/O processing and communications. Brains offer analog, digital, and serial functions, including thermocouple linearization; PID loop control; and optional high-speed digital counting (up to 20 kHz), quadrature counting, TPO, and pulse generation and measurement.

SNAP I/O

I/O provides the local connection to sensors and equipment. Opto 22 SNAP I/O offers 1 to 32 points of reliable I/O per module, depending on the type of module and your needs. Analog, digital, serial, and special-purpose modules are all mixed on the same mounting rack and controlled by the same processor (SNAP PAC brain or rack-mounted controller).

Quality

Founded in 1974 and with over 85 million devices sold, Opto 22 has established a worldwide reputation for high-quality products. All are made in the U.S.A. at our manufacturing facility in Temecula, California. Because we do no statistical testing and each part is tested twice before leaving our factory, we can guarantee most solid-state relays and optically isolated I/O modules for life.

Opto 22's Group offers free, comprehensive technical support for Opto 22 products. Our staff of support engineers represents decades of training and experience. is available in English and Spanish, by phone or email, Monday through Friday,

Free Customer Training

Hands-on training classes for the SNAP PAC System are offered at our headquarters in Temecula, California. Each student has his or her own learning station; classes are limited to nine students. Registration for the free training class is on a first-come, first-served basis. See our website, www.opto22.com for more information or email training@opto22.com.

contact Opto 22 headquarters at [951-695-3000](tel:951-695-3000) or visit our website at www.opto22.com